



HYDRAULIC TUBE FITTINGS

**➤ Unparalleled performance –
in manufacturing, quality,
supply and support**

FLUID POWER

- **1** Erembodegem: Gates European Headquarters
- **2** Esch (EMB): Tube Fitting Manufacturing
- **3** Euskirchen (EMB): Technical Center
- **4** Ghent: Distribution Centre
- **5** Moscow: Distribution Centre
- **6** Karvina: Coupling Manufacturing
- **6** Karvina: Hose Assembly Manufacturing
- **6** Karvina: Manipulated Tube Manufacturing
- **7** Legnica: Hose Manufacturing (as of Sept. 2018)
- **8** St Neots: Hose Assembly Manufacturing
- **8** St Neots: Technical Center
- **9** Sakarya: Hose Manufacturing





Every day, design engineers, maintenance people, equipment manufacturers and their customers around the world rely on Gates and our high quality line of hydraulic products to meet their fluid power needs and to keep their machines running smoothly, safely and reliably. Thanks to the Gates Integrated System Approach, all your fluid power products work together seamlessly.

From our global leadership position in hose assemblies, we have expanded our capabilities into tubing technology and complete port-to-port hydraulics:

- ▶ **Rigid Tube Assemblies**
- ▶ **Robotic Tube Bending & Welding**
- ▶ **Integrated hose/tube combinations**
- ▶ **Tube Fittings, End Forming & Adaptors**
- ▶ **VEVA (Value Engineering Value Analysis) & Services**

Wherever you are, the state-of-the-art technology in our production locations and assembly centres allow us to support OEM's around the world with customised just-in-time solutions to meet their tight schedules, volumes and high expectations. We also offer replacement market customers the right equipment to manufacture factory-quality product assembly on their own premises and be the nearby go-to distributor with the right solution to every breakdown.

All Gates tube line, tubes fittings, hose and adaptor products are designed and manufactured to provide innovative, reliable port-to-port solutions in an almost endless range of heavy equipment applications.

But we do not stop there. Based on our wide experience in hydraulics, hose development and leak-free hose/coupling interfaces, we have been expanding our product and market knowledge in other applications and systems over the last decades and we can now offer you Gates premium performance in industrial hoses, engine hoses and harsh roughneck oilfield applications alike.

The Gates service attitude is all about you: we help you keep costs down, make things easy to use, avoid downtime and loss of production, speed up installation, maintenance and repair - that's why people choose Gates.



Only a team where everyone plays their part and works together seamlessly can get a complex job done. Our hose and coupling components work together in just the same way, making it extremely simple to create high-quality hydraulic hose assemblies quickly for the equipment you're using.

This kind of easy self-assembly is based on the Gates Integrated System approach. All our hydraulic products are specifically designed, tested and validated together to produce pre-tested and validated hose/ coupling combinations that perform beyond any international standard.

This unique approach is how Gates ensures full compliance with the European Machinery Directive and the reason why Gates is known as the world's most trusted hydraulic hose assembly manufacturer. That is why Gates is your total fluid power solution.



**> Self-assembly
the Gates way saves
you time and effort**



THE WORLD OF TUBE FITTINGS

The Gates EMB range of tube fittings is an integral part of the Port-to-Port product portfolio of Gates. It ensures leak free connections between hydraulic tubes, hoses and adaptors.

The “made in Germany” quality ensures maximized reliability, even in critical applications. A leak-free design, with pressure safety factor 4, guarantees a ‘Safe Hydraulics’ environment with no spills or injuries. Through continuous testing and system validation we meet and exceed performance specifications. The Gates EMB connecting systems have received many 3rd party approvals. Easy to handle assembly machinery leads to zero failure rates. Our production and logistics concept allows for 98%+ service levels and high supply flexibility. Engineering support and CAD data lead to VA/VE optimization. The Gates EMB service attitude is all about you: we help you keep costs down, make things easy to use, avoid downtime and loss of production, speed up installation, maintenance and repair..... that’s why people choose Gates EMB.

CUSTOMER BENEFITS

- › Minimum operating costs/Maximum system up-time
- › Leak-free equals environment friendly
- › Reduced assembly time and costs
- › Short time-to-market
- › Reduction of Total Cost of Ownership

➤ ***With Gates EMB, you benefit from the strength and expertise of a global manufacturer, the innovative and reliable aspects of German engineering, and the convenience of a nearby distribution network, local product support and useful online tools. A winning combination by any standards.***

ZINC NICKEL AS STANDARD FINISHING

- Zinc Nickel coating is the new standard finishing for Gates EMB tube fittings.
- With a corrosion protection against red rust of more than 720 hours (acc. to ISO 9227) it provides a significantly better surface protection than the previous NanoProtect™ material and easily reaches protection class K5 of the VDMA24576 standard.
- Compliant with the latest REACH and RoHS2 requirements, fulfilling its environmental duties.
- Zinc Nickel products can be used in a variety of applications in the Agriculture, Construction, Engineering and Renewable Energy industries.
- On special request, for use in high temperature environments or where no corrosion is allowed, like Food, Chemical, Pharmaceutical or Marine applications, Gates EMB offers high quality 1.4571 grade Stainless Steel components.
- For a more economical solution and where surface protection is of lesser importance, NanoProtect™ can still be offered as a non-standard item.
- Regardless of your requirement, Gates EMB offers the right hydraulic tube fittings to meet your challenging applications each and every time!

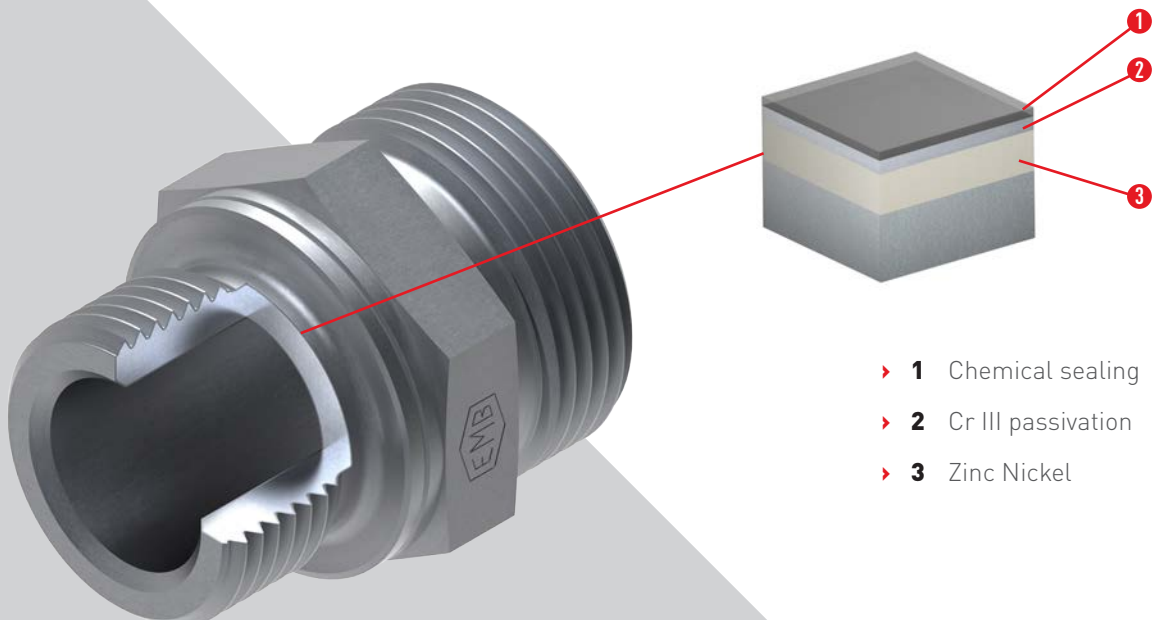

- **1** Chemical sealing
- **2** Cr III passivation
- **3** Zinc Nickel

1. CONNECTORS



Connectors can be used to connect metric tubes, hoses and fittings to each other in whatever configuration. They are divided into 3 ranges:

- › very light
- › light
- › and heavy series

Designed for nominal pressures up to 800 bar (heavy series) and available in various geometries such as

- › straight
- › elbow (e.g. 45° and 90°)
- › tee
- › cross

2. MALE STUD TUBE FITTINGS



Male stud fittings allow the connection of a metric tube with a port. From metric stud end with captive seal to the imperial stud end with Form A, Gates EMB offers a wide range of stud end fittings. Male stud tube fittings are available in (according to ISO 8434-1 / DIN 2353)

- › very light
- › light
- › and heavy series

Designed for nominal pressures up to 800 bar (heavy series) and available in various geometries such as

- › straight
- › elbow (e.g. 45° and 90°)
- › and tee

› **Find out more at www.emb-eifel.de**

3. ADJUSTABLE TUBE FITTINGS



Adjustable tube fittings allow the connection of minimum one metric tube with another tube fitting or port and can be assembled in any direction. Adjustable tube fittings are available (according to ISO 8434-1 / DIN 2353) in

- ▶ very light
- ▶ light
- ▶ and heavy series

Designed for nominal pressures up to 800 bar (heavy series) and available in various geometries such as

- ▶ elbow (e.g. 45° and 90°)
- ▶ and tee

4. REDUCERS AND GAUGE FITTINGS



Reducers are straight fittings and are used to reduce from one thread size to another thread size or from one metric tube size to another. Reducers thread to thread are not classified in series like connectors or male stud fittings. Reducers metric tube to metric tube (DKO) are classified (according to ISO 8434-1 / DIN 2353) in

- ▶ very light
- ▶ light
- ▶ and heavy series

Designed for nominal pressures up to 800 bar (heavy series).

Gauge fittings are straight fittings, which are used to connect a gauge with another fitting, tube or hose. Available with standard 24° cone, DKO or standpipe in

- ▶ very light
- ▶ light
- ▶ and heavy series

Designed for nominal pressures up to 630 bar (heavy series).

5. VALVES



Check valves allow the connection of metric tube to metric tube or tube to hose or to port. Check valves control the flow in a hydraulic system and open at a defined fixed pressure. Standard opening pressure for RD, RV and RZ is 1,0 bar. Other opening pressures are marked on the valve to allow a clear identification of opening pressure.

Valves are available in

- ▶ light
- ▶ and heavy series. (according to ISO 8434-1 / DIN 2353)

Designed for nominal pressures up to 400 bar (heavy series).

ARV valves are only available in very light series with pressure ratings up to 100 bar. While RD, RV and RZ are coned valves, the ARV are ball valves. Typical applications for these valves are mainly lubrication lines.

6. ACCESSORIES



Accessories have a high variety, from plugs in different sealing forms and sizes to sealing rings or support sleeves. This range contains every component to complete your hydraulic fittings range.

▶ **Find out more at www.emb-eifel.de**

7. CONTROL SYSTEM



Gates EMB offers a wide range of test couplings, test hoses, pressure gauges and other accessories according to international standards. The extensive range allows our customers to buy tube fittings and control system from one single source.

To fulfill customer expectations, the Gates EMB range contains different systems with M16x2, M16x1,5 or plug-in test connections.

Benefits:

- ▶ Enables safe system pressure checks
- ▶ Leak-proof connection before cone / ball valve is open
- ▶ Simple connection with measuring, control and switching devices
- ▶ Self-locking metal guard cap

8. CONNECTING SYSTEMS (WELDING NIPPLES, FLARING, CUTTING RINGS, FS)



Gates EMB provides different connecting systems that fit the standardised tube fitting range.

The cutting ring is the most common connecting system for tube fittings. Gates EMB double edge cutting ring and double edge cutting ring with soft seal in combination with our final-assembly machine OPTICAM 4S are a strong and valuable solution for serial production.

The Gates EMB FS System with its low degree of deformation is an excellent alternative in areas where no cutting ring or flaring is allowed.

The ABO system of Gates EMB is a soft sealed connection used instead of a JIC connection, which allows the customer to use DIN tube fittings and reduce the risk of leakages.

THE WORLD OF ASSEMBLY MACHINERY

EMB-FS® CONNECTION TECHNOLOGY: EASY, QUICK AND RELIABLE

The innovative 'Form & Seal' system was designed for the connection of tubes without specific tube preparation and finishing. It boasts the advantages of a welding system but the number of necessary single parts is reduced to the minimum, optimising the cost-performance ratio and minimising the system costs. The system can also be used for nearly all applications as we provide a comprehensive product portfolio of DIN 2353, ISO 8434-1 tube fittings. The EMB-FS® system and assembly procedure guarantees you minimum tube stress, fast assembly and maximum retention forces

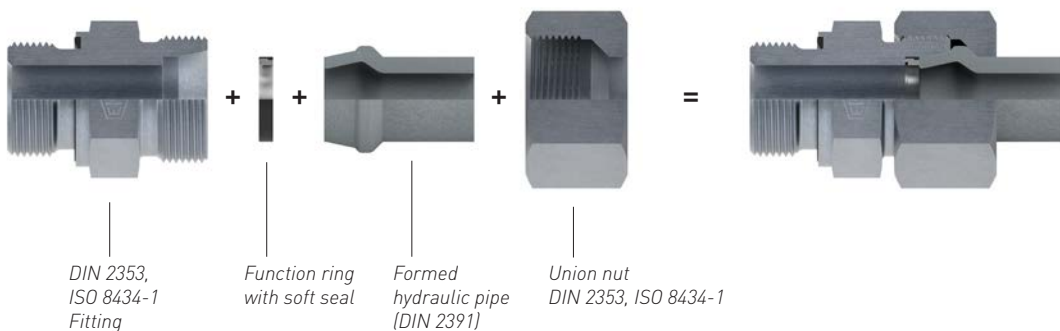

No compromises, no difficulties

A function ring supports the final assembly. It integrates an elastomer seal into the system and protects against excessive tightening. Frictional tension between tube and fitting cone is assured with the metallic seal function. Vulcanised soft seals ensure the leak-free performance in extreme working conditions as well. Safe assembly is indicated by a clearly noticeable assembly stop.

**MORE CONTROL-MORE SAFETY-EVEN EASIER!
THE NEW GATES EMB OPTICAM 4S**



Our new final assembly machine OPTICAM 4S by GATES EMB is available now.

25 years after the OPTICAM 642, the first machine for the controlled final assembly of hydraulic tube fittings, EMB offers with the OPTICAM 4S a new generation of machine.

Advantages

- ▶ Optimized assembly safety due to improved hardware and software!
- ▶ Simplified operation by a new user interface panel!
- ▶ Simplified data transfer for the optimized data evaluation & analysis!

CUTTING RING ASSEMBLY & FLARING MACHINERY



UNIPRESS 3: Universal machine for flaring and cutting ring pre-assembly

Today, cutting ring and flaring are still the main technologies used to connect tubes. To guarantee leak-free results, the joint procedure requires reliable machines that support the quality of the connection. Thanks to the Gates assembly machines' accurate processes, a minimum of the operator's individual intervention is required, reducing the need for manual justifications as well as process control.

➤ Find out more on assembly machinery

TUBE END FORMING & TUBE MANIPULATION MACHINERY

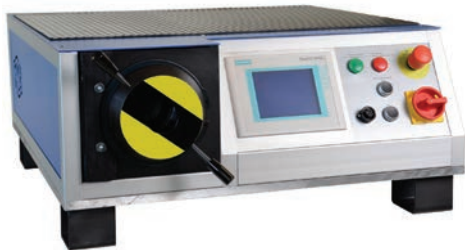

FS 93: Tube forming machine

Tube forming is not only one of the safest methods for the connection of leak-free hydraulic tube systems but can be used as an alternative for expensive welding procedures in many cases. The result is a huge cost reduction on both labour and system assembly cost. This supports economies of scale and provides extra time and money for further projects. Operator faults are basically excluded due to automated machine functions. Gates-EMB assembly machines are developed with individual customer needs in mind like ease of use, reliability and cost performance.

CUTTING MACHINES

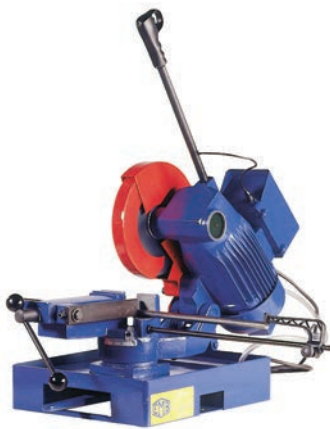

UNICUT TC 080: Metal circular saw

Gates EMB steel tube cutters are robust and compact machines, and distinguish themselves by their safe and high-quality cutting function. Our range of electrical cutters is all hand controlled for guided cutting thus allowing for optimal speed control and a reduction of blade damage. The blades are positioned close to the powerful motors to limit vibration which enhances the durability and reduces maintenance costs. But there is more: low energy consumption, CE compliant brake motors for 3-phase cutting machines, built-in protection, limited smoke production ... all supporting your safe working environment and personnel safety.

at www.emb-eifel.de

SAFETY FIRST – USE GATES TO HELP YOU

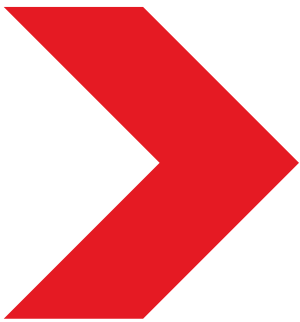

When working with hydraulic equipment, it's important to be aware of the potential dangers and never to underestimate the power of a hydraulic hose or tube assembly under pressure. Having the world's best hoses, couplings and fittings is not enough to ensure the safety of your hydraulic assemblies. Poor assembly, a bad installation or an incorrect method of storage can compromise performance and even safety.

THE GATES SAFE HYDRAULICS PROGRAMME: THINK SAFETY!

Your safety and that of your workforce, your customer and the environment is always a top priority for us. That's why we offer all our customers the Safe Hydraulics Programme, a safety and preventive maintenance training seminar. The programme is designed by Gates application engineers and run by experienced and certified trainers.

Our seminars can be tailored to match your needs, but most include the following topics:

- ▶ How to work safely and how to reduce your risks and protect the environment
- ▶ The entire safety process: storage, selection, installation and inspection
- ▶ How to avoid material and personal hazards and liability issues
- ▶ Expert information on safety issues affecting hydraulic hose assemblies



The seminar can accommodate people from all industries, backgrounds and levels of hydraulic knowledge.

Book your place on a seminar through your authorised Gates distributor or partner. To find out more please go to our website www.safehydraulicseurope.com or ask for our Safe Hydraulics pocket guide.

KEEPING YOU UP TO DATE WITH SAFETY AND LEGISLATION

In Europe the main safety Directive covering hose and machinery products is the European Machinery Directive 2006/42/EC. This provides the regulatory basis for the harmonisation of essential health and safety requirements for machinery at European Union level. In practical terms, however, the best way to be sure you're complying with the Directive is to comply with the Harmonised European Standards. These standards are tools that help manufacturers and users comply with the Directive by giving you practical guidance on how to meet its requirements. The two most important standards on safety requirements for hydraulic hose assemblies are:

- › ISO 12100:2010
(‘Safety of machinery: Basic concepts, general principles for design’)
- › ISO 4413:2010 (‘Safety of machinery – Safety requirements for fluid power systems and their components – Hydraulics’)

The good news is that the Gates Integrated System of hoses, couplings, self-assembly machines and crimp data – used together – ensure you fully comply with this European Machinery Directive.



› ***Gates, safety is more than a priority – it's part of everything we do***

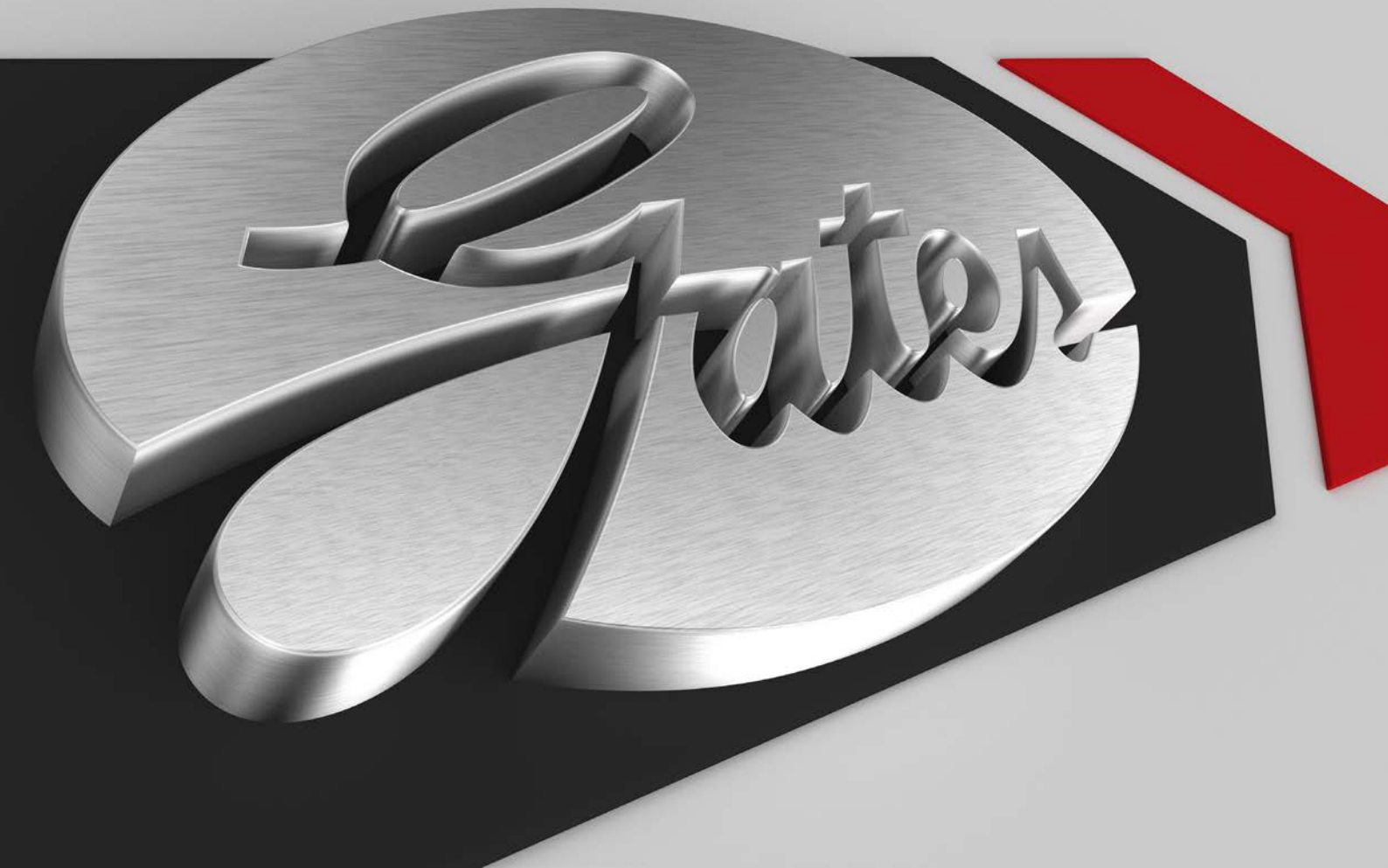

HEADQUARTERS BELGIUM

GATES EUROPE BVBA

Korte Keppestraat 21/51
9320 Ereembodegem

T (32) 53 76 27 11 / **F** (32) 53 76 29 22

Gates.com/europe/industrial

inforequest@gates.com

GERMANY

EIFELER MASCHINENBAU GmbH

Kolumbusstraße 54
D-53881 Euskirchen

T (49) 2251 1256-0 / **F** (49) 2251 1256-400

Emb-eifel.de

info@emb-eifel.de

INDIA

GATES INDIA PVT LTD

3rd Floor, Building Number 10, Tower C
DLF Cyber City, Phase 2,
Gurgaon, Haryana - 122 002.

T (91) 124 4933535

Gates.com/india

customer.care@gates.com

AMERICAS

GATES CORPORATION

1551 Wewatta Street
Denver, CO 80202

T (1) 303 744 4087 / **F** (1) 303 744 5278

Gates.com

EAST ASIA HQ

GATES SINGAPORE

3A International Business Park ICON@IBP,
Lobby A, #10-01/05
Singapore 609935

T (65) 6861 7322 Ext 15

F (65) 6861 7631 / 6862 4661

Gates.com

sales.gess@gates.com

CHINA

GATES TRADING (SHANGHAI) CO. LTD

Rm 603-604 Tower A Oriento Plaza, No 388
Fuquan North Road, Changning District
Shanghai, P.R.China 200335

上海市长宁区福泉北路388号东方国信商务楼A
座603-604室 邮编: 200335

T (86) 21 8031 7000

Gates.com

Your distributor: