

ASSEMBLY INSTRUCTION FLANGE TUBE JOINTS ABO

1. Cut off tube to be laid at a right angle.



Do not use a tube cutter!

2. Deburr tube on inside and outside, do not chamfer! Permissible chamfering inside and outside $0.2 \times 45^\circ$
3. Clean tube on inside and outside.
4. Oil* flange screw connection parts and push over the end of tube push.
5. Bend up tube in flaring machine e.g. EMB UNIPRESS 3. The tulip flare is to be checked for cracks after the flange procedure and if necessary the flanged tube is to be replaced. Examine the diameters of the tulip flare, see tab. Check the flanged tube.
6. Final assembly with loose flange adapter

Insert flange adapters into screw connection and attach bent up tube to adapters. Tighten union nut until there is a clearly noticeable increase in force [pressure point]. The flange adapter is hereby pressed into the connecting pieces. The following final assembly amounts to:

6-L to 12-L = 1/4 turn
15-L to 42-L = 1/2 turn
6-S to 38-S = 1/2 turn.

Final assembly with PRESSED in flange adapter

Clamp flange adapter and screw connection into a vice and slowly tighten. As soon as the gap between flange adapter a screw connection has disappeared, the adapter is pushed in fully.



It must be ensured that neither the screw connection nor flange adapter is damaged!

Tighten union nut until there is a clearly noticeable increase in force [pressure point], then final assembly:

6-L to 12-L = 1/4 turn
15-L to 42-L = 1/2 turn
6-S to 38-S = 1/2 turn.

* With screw connection parts made of stainless steel [e.g. 1.4571] a pasty lubricant [e.g. EMB lubricant paste] must be used.

Repeat assembly

Each time after the connection is loosened the union nut must be tightened with the same torque as with the previous assembly.

FLANGE TUBE JOINTS

Tube length specification

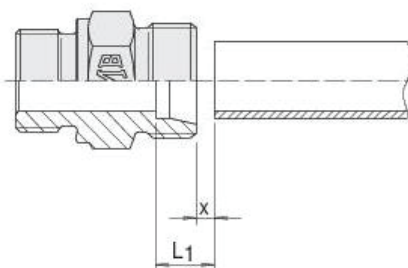

The tube length specification is carried out by measuring from the front side of the connecting piece to the front side of the tube. The measurement X is then to be subtracted for each tube connection.

Tube dim.	X	L1	Tube dim.	X	L1	Tube dim.	X	L1
6x1	1	8	16x1,5	0	8,5	28x2	1,5	9
6x1,5	2	9	16x2	1	9,5	28x2,5	2,5	10
8x1	1	8	16x2,5	1,5	10	28x3	3	10,5
8x1,5	2	9	16x3	2,5	11	30x2	0,5	13
8x2	2,5	9,5	18x1,5	0	7,5	30x2,5	0,5	14
10x1	1	8	18x2	1	8,5	30x3	1	14,5
10x1,5	2	9	18x2,5	1,5	9	30x4	3	16,5
10x2	3	10	20x2	1	11,5	30x5	4,5	18
12x1	1	8	20x2,5	2	12,5	35x2	1,5	12
12x1,5	2	9	20x3	3	13,5	35x2,5	2	12,5
12x2	3	10	20x3,5	4	14,5	35x3	3	13,5
14x1,5	0,5	8,5	22x1,5	1	8,5	35x4	4,5	15
14x2	1	9	22x2	2	9,5	38x2,5	0	16
14x2,5	2	10	22x2,5	3	10,5	38x3	0,5	16,5
14x3	3	11	22x3	3,5	11	38x4	2	18
15x1,5	1	8	25x2	1	13	38x5	4	20
15x2	2	9	25x2,5	1,5	13,5	42x2	1,5	12,5
15x2,5	3	10	25x3	2,5	14,5	42x3	3	14
			25x4	4	16	42x4	4,5	15,5

EXAMINATION OF THE FLANGED TUBE

Tube right-angled separated, inside and outside easily deburrs. Not chamfered!

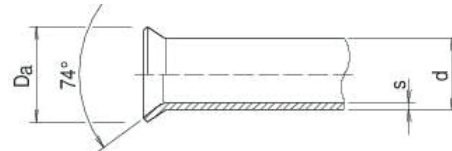
IMPORTANT

Too short flange collars, e.g. as a result of operating errors or assembly pressures set too low, do not guarantee the perfect function of the screw connection! For the correct diameter of the flange collar, see the control diameter table below diameters min and max.

Tube dim. dxs	Control dia. Da min	Control dia. Da max	Tube dim. dxs	Control dia. Da min	Control dia. Da max	Tube dim. dxs	Control dia. Da min	Control dia. Da max
6x1	9,1	10	16x1,5	20,6	22	28x2	32,7	33,3
6x1,5	9,1	10	16x2	20,6	22	28x2,5	32,7	33,3
8x1	11,3	12	16x2,5	20,6	22	28x3	32,7	33,3
8x1,5	11,3	12	16x3	20,6	22	30x2	37	38,7
8x2	11,3	12	18x1,5	23,2	24	30x2,5	37	38,7
10x1	13,1	14	18x2	23,2	24	30x3	37	38,7
10x1,5	13,1	14	18x2,5	23,2	24	30x4	37	38,7
10x2	13,1	14	20x2	25,6	26,8	30x5	37	38,7
12x1	15,3	16	20x2,5	25,6	26,8	35x2	41,8	42,7
12x1,5	15,3	16	20x3	25,6	26,8	35x2,5	41,8	42,7
12x2	15,3	16	20x3,5	25,6	26,8	35x3	41,8	42,7
14x1,5	18,6	19,6	22x1,5	26,5	27,5	35x4	41,8	42,7
14x2	18,6	19,6	22x2	26,5	27,5	38x2,5	46	47,2
14x2,5	18,6	19,6	22x2,5	26,5	27,5	38x3	46	47,2
14x3	18,6	19,6	22x3	26,5	27,5	38x4	46	47,2
15x1,5	19,1	20	25x2	31,1	33	38x5	46	47,2
15x2	19,1	20	25x2,5	31,1	33	42x2	48,8	49,8
15x2,5	19,1	20	25x3	31,1	33	42x3	48,8	49,8
			25x4	31,1	33	42x4	48,8	49,8

CORRECTION TABLE FOR CONSTRUCTION LENGTHS

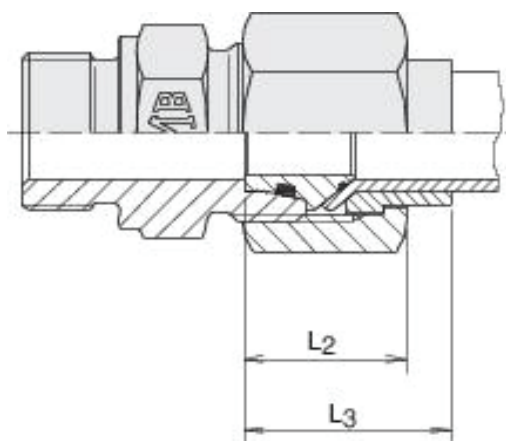

Series	Tube OD	L2	L3
L	6	17,5	20,5
	8	18,5	21,5
	10	19,5	24,
	12	20	24,5
	15	21,5	25,5
	18	23	27
	22	24	30,5
	28	26	31,5
	35	30	36
	42	34	40
S	6	17,5	20,5
	8	18,5	21,5
	10	20	24,5
	12	20,5	25
	16	25	31
	20	27,5	33
	25	31	38,5
	30	33	41,5
	38	37,5	48

The tube wall thicknesses marked in the following correction table with an X are based on the construction lengths in the previous table. For other tube wall thicknesses, the overall lengths are to be changed by the correction measure that can be inferred from the table.

Correction measure / tube wall thickness

Tube OD	Series	1	1,5	2	2,5	3	3,5	4	5	
6	L	X	+1							
8		X	+1	1,5						
10		-1	X	+1						
12		-1	X	+1						
15			X	+1	+2					
18			-1	X	+1					
22			-1	X	+1	+1,5				
28					-1,5	-0,5	X			
35					-1,5	-1	X		+1,5	
42					-1,5		X		+1,5	
6	S	X	+1							
8		X	+1	+1,5						
10		-1	X	+1						
12		-1	X	+1						
16			-1	X	+0,5	+1,5				
20				X	+1	+2	3			
25					-1,5	-1	X		+1,5	
30					-2	-1	X		+2	+3,5
38						-0,5	X		1,5	+3,5

STRAIGHT TUBE LENGTH UNTIL BENDING RADIUS COMMENCEMENT

“First bend - then flare”

Straight tube end (dimensions L1) until bending radius commencement with flares

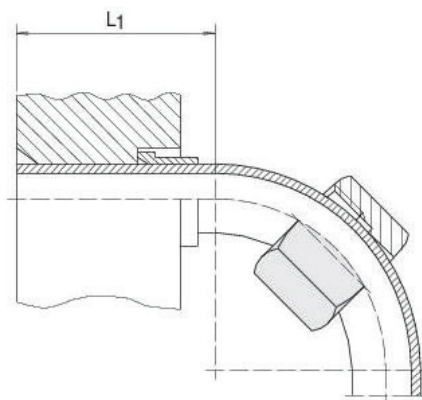

Tube	Flaring machine UNIPRESS L1
6	43
8	44
10	46
12	47
15	50
16	52
18	58
20	58
22	60
25	60
28	60
30	62
35	62
38	70
42	70

“First flare - then bend”

If the straight tube end [dimensions L2] is smaller than specified in the table as a result of installation difficulties, bending must take place after flaring.

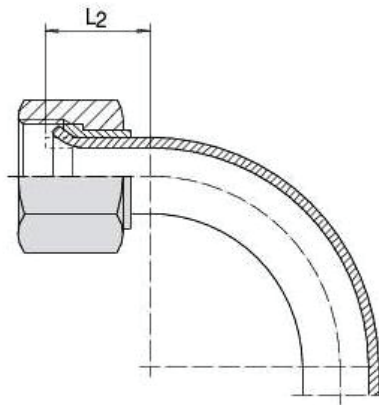

Tube OD	L2
10	15
12	15
15	17
16	21
18	18

Tube OD 6,8 on request

Tube quality

We recommend the use of seamless precision steel tube with dimensions in accordance with DIN EN ISO 10305 Part 4, Material: E235, NBK.

Tubes from rust and acid-proof material must be seamlessly cold-drawn, scale-free and heat-treated in accordance with DIN EN 10216-5 - X6 CrNiMoTi17-12-2-CFD and exhibit tolerances in accordance with DIN EN ISO 10305-1.